

SI98.00-P-0015A	Service Information: Painting bumpers with short range radar	18.8.15
-----------------	--	---------

- Model 463*
with code EA2 (Blind Spot Assist)
- Model 463*
with code EZ8 (PARKTRONIC)
- Model 463*
with code EZ9 (DISTRONIC PLUS)
- Model all*
with code 229 (Park Assist)
- Model all*
with code 230 (Advanced Parking Guidance)
- Model all*
with code 233 (DISTRONIC PLUS)
- Model all*
with code 234 (Blind Spot Monitoring)
- Model all*
with code 235 (Active Parking Assist with PARKTRONIC)
- Model all*
with code 239 (DISTRONIC PLUS)

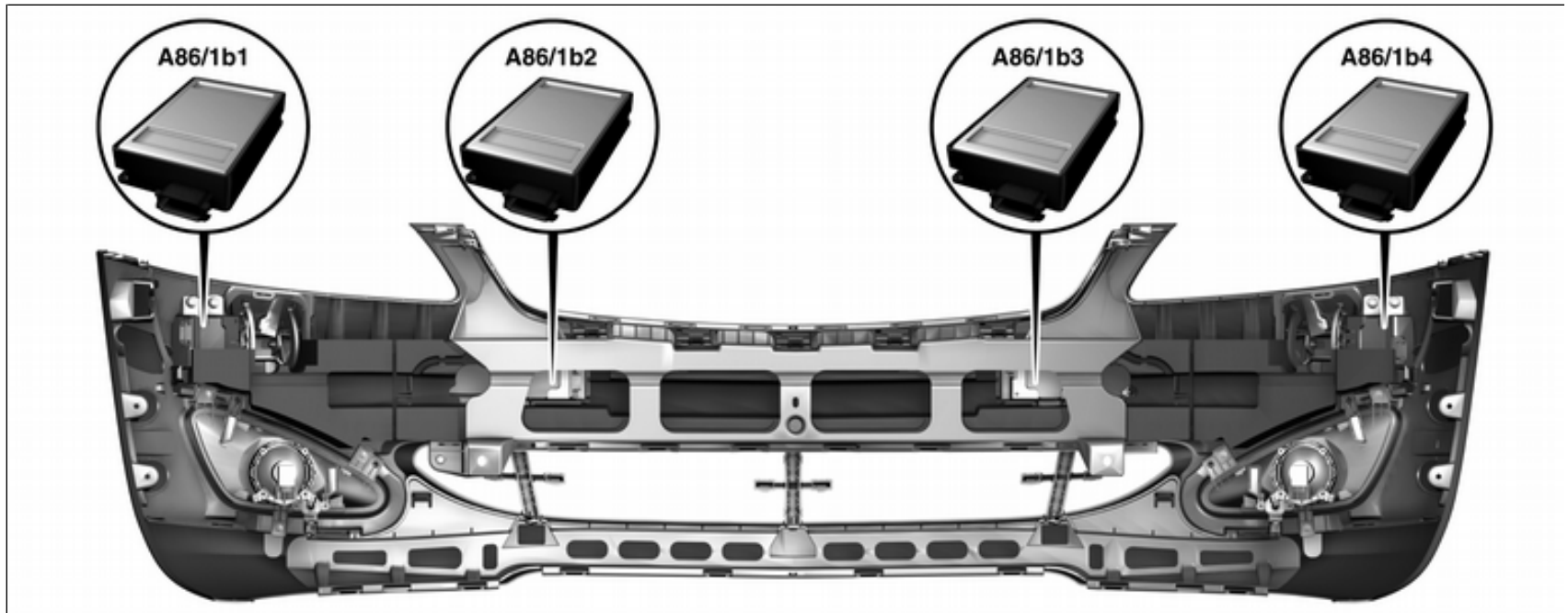

P30.30-2075-08

Location of radar sensors in front bumper, shown on model 221

A86/1b1 Left outer radar sensor

A86/1b2 Left inner radar sensor

A86/1b3 Right inner radar sensor

A86/1b4 Right outer radar sensor

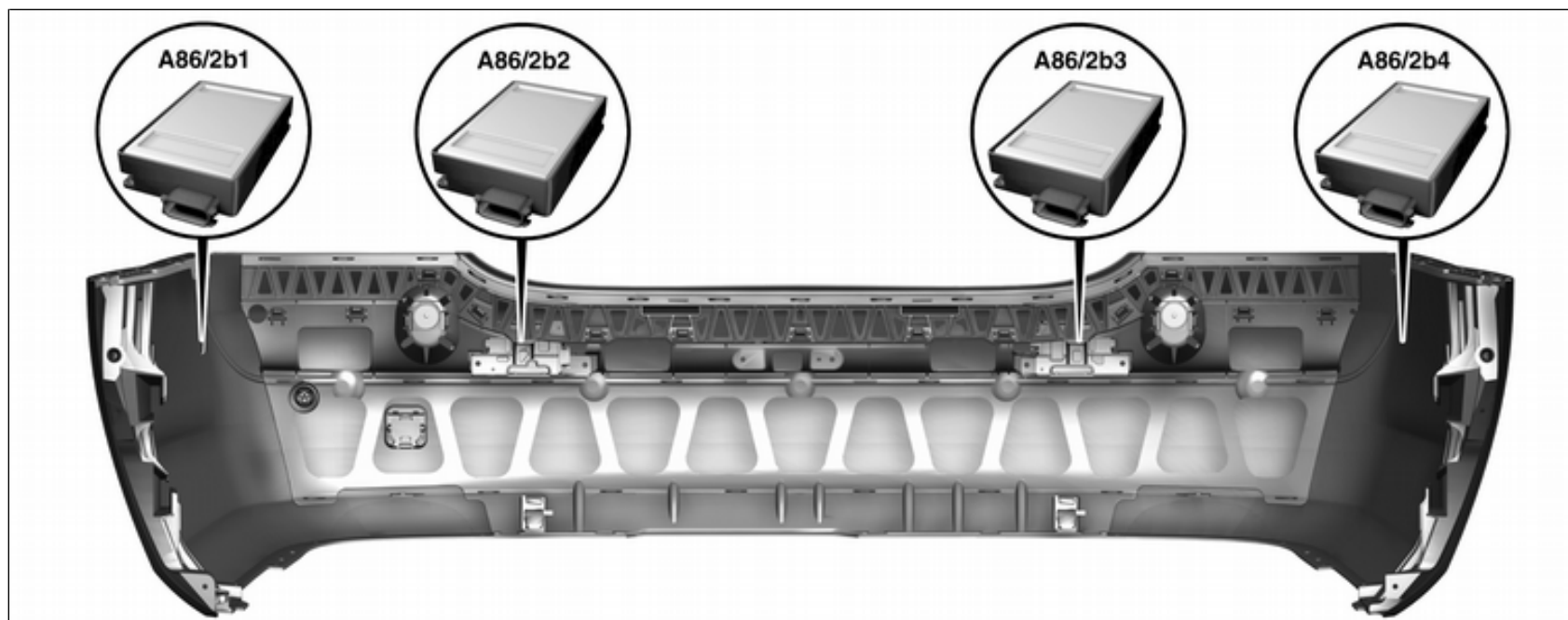

P30.30-2076-08

Location of radar sensors in rear bumper, shown on model 221

A86/2b1 Right outer radar sensor

A86/2b2 Right inner radar sensor

A86/2b3 Left inner radar sensor

A86/2b4 Left outer radar sensor

i When performing filling and painting work on the bumpers, it is important to make sure that the maximum coat thickness is not exceeded at the short range radar sensors. This can lead to malfunctions as the sensors detect the excessive coat thickness as an obstacle. The limit value for the coat thickness at the sensors is two coats of paint.

i If the short range radar does not function correctly after painting, either the paint must be removed or the bumper must be replaced.